

User's Manual



SW8 VGA Ars



SW12 VGA Ars

SW8/12 VGA Ars

Computer Video and Audio Switchers

Precautions

Safety Instructions • English



This symbol is intended to alert the user of important operating and maintenance (servicing) instructions in the literature provided with the equipment.



This symbol is intended to alert the user of the presence of uninsulated dangerous voltage within the product's enclosure that may present a risk of electric shock.

Caution

Read Instructions • Read and understand all safety and operating instructions before using the equipment.

Retain Instructions • The safety instructions should be kept for future reference.

Follow Warnings • Follow all warnings and instructions marked on the equipment or in the user information.

Avoid Attachments • Do not use tools or attachments that are not recommended by the equipment manufacturer because they may be hazardous.

Consignes de Sécurité • Français



Ce symbole sert à avertir l'utilisateur que la documentation fournie avec le matériel contient des instructions importantes concernant l'exploitation et la maintenance (réparation).



Ce symbole sert à avertir l'utilisateur de la présence dans le boîtier de l'appareil de tensions dangereuses non isolées posant des risques d'électrocution.

Attention

Lire les instructions • Prendre connaissance de toutes les consignes de sécurité et d'exploitation avant d'utiliser le matériel.

Conservier les instructions • Ranger les consignes de sécurité afin de pouvoir les consulter à l'avenir.

Respecter les avertissements • Observer tous les avertissements et consignes marqués sur le matériel ou présentés dans la documentation utilisateur.

Eviter les pièces de fixation • Ne pas utiliser de pièces de fixation ni d'outils non recommandés par le fabricant du matériel car cela risquerait de poser certains dangers.

Sicherheitsanleitungen • Deutsch



Dieses Symbol soll dem Benutzer in der im Lieferumfang enthaltenen Dokumentation besonders wichtige Hinweise zur Bedienung und Wartung (Instandhaltung) geben.



Dieses Symbol soll den Benutzer darauf aufmerksam machen, daß im Inneren des Gehäuses dieses Produktes gefährliche Spannungen, die nicht isoliert sind und die einen elektrischen Schock verursachen können, herrschen.

Achtung

Lesen der Anleitungen • Bevor Sie das Gerät zum ersten Mal verwenden, sollten Sie alle Sicherheits- und Bedienungsanleitungen genau durchlesen und verstehen.

Aufbewahren der Anleitungen • Die Hinweise zur elektrischen Sicherheit des Produktes sollten Sie aufbewahren, damit Sie im Bedarfsfall darauf zurückgreifen können.

Befolgen der Warnhinweise • Befolgen Sie alle Warnhinweise und Anleitungen auf dem Gerät oder in der Benutzerdokumentation.

Keine Zusatzgeräte • Verwenden Sie keine Werkzeuge oder Zusatzgeräte, die nicht ausdrücklich vom Hersteller empfohlen wurden, da diese eine Gefahrenquelle darstellen können.

Instrucciones de seguridad • Español



Este símbolo se utiliza para advertir al usuario sobre instrucciones importantes de operación y mantenimiento (o cambio de partes) que se desean destacar en el contenido de la documentación suministrada con los equipos.



Este símbolo se utiliza para advertir al usuario sobre la presencia de elementos con voltaje peligroso sin protección aislante, que puedan encontrarse dentro de la caja o alojamiento del producto, y que puedan representar riesgo de electrocución.

Precaucion

Leer las instrucciones • Leer y analizar todas las instrucciones de operación y seguridad, antes de usar el equipo.

Conservar las instrucciones • Conservar las instrucciones de seguridad para futura consulta.

Obedecer las advertencias • Todas las advertencias e instrucciones marcadas en el equipo o en la documentación del usuario, deben ser obedecidas.

Evitar el uso de accesorios • No usar herramientas o accesorios que no sean específicamente recomendados por el fabricante, ya que podrían implicar riesgos.

安全须知 • 中文



这个符号提示用户该设备用户手册中有重要的操作和维护说明。



这个符号警告用户该设备机壳内有暴露的危险电压，有触电危险。

注意

阅读说明书 • 用户使用该设备前必须阅读并理解所有安全和使用说明。

保存说明书 • 用户应保存安全说明书以备将来使用。

遵守警告 • 用户应遵守产品和用户指南上的所有安全和操作说明。

避免追加 • 不要使用该产品厂商没有推荐的工具或追加设备，以避免危险。

Warning

Power sources • This equipment should be operated only from the power source indicated on the product. This equipment is intended to be used with a main power system with a grounded (neutral) conductor. The third (grounding) pin is a safety feature, do not attempt to bypass or disable it.

Power disconnection • To remove power from the equipment safely, remove all power cords from the rear of the equipment, or the desktop power module (if detachable), or from the power source receptacle (wall plug).

Power cord protection • Power cords should be routed so that they are not likely to be stepped on or pinched by items placed upon or against them.

Servicing • Refer all servicing to qualified service personnel. There are no user-serviceable parts inside. To prevent the risk of shock, do not attempt to service this equipment yourself because opening or removing covers may expose you to dangerous voltage or other hazards.

Slots and openings • If the equipment has slots or holes in the enclosure, these are provided to prevent overheating of sensitive components inside. These openings must never be blocked by other objects.

Lithium battery • There is a danger of explosion if battery is incorrectly replaced. Replace it only with the same or equivalent type recommended by the manufacturer. Dispose of used batteries according to the manufacturer's instructions.

Avertissement

Alimentations • Ne faire fonctionner ce matériel qu'avec la source d'alimentation indiquée sur l'appareil. Ce matériel doit être utilisé avec une alimentation principale comportant un fil de terre (neutre). Le troisième contact (de mise à la terre) constitue un dispositif de sécurité : n'essayez pas de la contourner ni de la désactiver.

Déconnexion de l'alimentation • Pour mettre le matériel hors tension sans danger, déconnectez tous les cordons d'alimentation de l'arrière de l'appareil ou du module d'alimentation de bureau (s'il est amovible) ou encore de la prise secteur.

Protection du cordon d'alimentation • Acheminer les cordons d'alimentation de manière à ce que personne ne risque de marcher dessus et à ce qu'ils ne soient pas écrasés ou pincés par des objets.

Réparation-maintenance • Faire exécuter toutes les interventions de réparation-maintenance par un technicien qualifié. Aucun des éléments internes ne peut être réparé par l'utilisateur. Afin d'éviter tout danger d'électrocution, l'utilisateur ne doit pas essayer de procéder lui-même à ces opérations car l'ouverture ou le retrait des couvercles risquent de l'exposer à de hautes tensions et autres dangers.

Fentes et orifices • Si le boîtier de l'appareil comporte des fentes ou des orifices, ceux-ci servent à empêcher les composants internes sensibles de surchauffer. Ces ouvertures ne doivent jamais être bloquées par des objets.

Lithium Batterie • Il a danger d'explosion s'il y a remplacement incorrect de la batterie. Remplacer uniquement avec une batterie du même type ou d'un type équivalent recommandé par le constructeur. Mettre au rebut les batteries usagées conformément aux instructions du fabricant.

Vorsicht

Stromquellen • Dieses Gerät sollte nur über die auf dem Produkt angegebene Stromquelle betrieben werden. Dieses Gerät wurde für eine Verwendung mit einer Hauptstromleitung mit einem geerdeten (neutralen) Leiter konzipiert. Der dritte Kontakt ist für einen Erdschluß, und stellt eine Sicherheitsfunktion dar. Dieses sollte nicht umgangen oder außer Betrieb gesetzt werden.

Stromunterbrechung • Um das Gerät auf sichere Weise vom Netz zu trennen, sollten Sie alle Netzkabel aus der Rückseite des Gerätes, aus der externen Stromversorgung (falls dies möglich ist) oder aus der Wandsteckdose ziehen.

Schutz des Netzkabels • Netzkabel sollten stets so verlegt werden, daß sie nicht im Weg liegen und niemand darauf treten kann oder Objekte darauf- oder unmittelbar dagegengestellt werden können.

Wartung • Alle Wartungsmaßnahmen sollten nur von qualifiziertem Servicepersonal durchgeführt werden. Die internen Komponenten des Gerätes sind wartungsfrei. Zur Vermeidung eines elektrischen Schocks versuchen Sie in keinem Fall, dieses Gerät selbst öffnen, da beim Entfernen der Abdeckungen die Gefahr eines elektrischen Schlags und/oder andere Gefahren bestehen.

Schlitze und Öffnungen • Wenn das Gerät Schlitze oder Löcher im Gehäuse aufweist, dienen diese zur Vermeidung einer Überhitzung der empfindlichen Teile im Inneren. Diese Öffnungen dürfen niemals von anderen Objekten blockiert werden.

Lithium-Batterie • Explosionsgefahr, falls die Batterie nicht richtig ersetzt wird. Ersetzen Sie verbrauchte Batterien nur durch den gleichen oder einen vergleichbaren Batterietyp, der auch vom Hersteller empfohlen wird. Entsorgen Sie verbrauchte Batterien bitte gemäß den Herstelleranweisungen.

Advertencia

Alimentación eléctrica • Este equipo debe conectarse únicamente a la fuente/tipo de alimentación eléctrica indicada en el mismo. La alimentación eléctrica de este equipo debe provenir de un sistema de distribución general con conductor neutro a tierra. La tercera pata (puesta a tierra) es una medida de seguridad, no puentearla ni eliminarla.

Desconexión de alimentación eléctrica • Para desconectar con seguridad la acometida de alimentación eléctrica al equipo, desenchufar todos los cables de alimentación en el panel trasero del equipo, o desenchufar el módulo de alimentación (si fuera independiente), o desenchufar el cable del receptáculo de la pared.

Protección del cables de alimentación • Los cables de alimentación eléctrica se deben instalar en lugares donde no sean pisados ni apretados por objetos que se puedan apoyar sobre ellos.

Reparaciones/mantenimiento • Solicitar siempre los servicios técnicos de personal calificado. En el interior no hay partes a las que el usuario deba acceder. Para evitar riesgo de electrocución, no intentar personalmente la reparación/mantenimiento de este equipo, ya que al abrir o extraer las tapas puede quedar expuesto a voltajes peligrosos u otros riesgos.

Ranuras y aberturas • Si el equipo posee ranuras o orificios en su caja/alojamiento, es para evitar el sobrecalentamiento de componentes internos sensibles. Estas aberturas nunca se deben obstruir con otros objetos.

Batería de litio • Existe riesgo de explosión si esta batería se coloca en la posición incorrecta. Cambiar esta batería únicamente con el mismo tipo (o su equivalente) recomendado por el fabricante. Desachar las baterías usadas siguiendo las instrucciones del fabricante.

警告

电源 • 该设备只能使用产品上标明的电源。设备必须使用有地线的供电系统供电。第三条线（地线）是安全设施，不能不用或跳过。

拔掉电源 • 为安全地从设备拔掉电源，请拔掉所有设备后或桌面电源的电源线，或任何接到市电系统的电源线。

电源线保护 • 妥善布线，避免被踩踏，或重物挤压。

维护 • 所有维修必须由认证的维修人员进行。设备内部没有用户可以更换的零件。为避免出现触电危险不要自己试图打开设备盖子维修该设备。

通风孔 • 有些设备机壳上有通风槽或孔，它们是用来防止机内敏感元件过热。不要用任何东西挡住通风孔。

锂电池 • 不正确的更换电池会有爆炸的危险。必须使用与厂家推荐的相同或相近型号的电池。按照生产厂的建议处理废弃电池。

FCC Class A Notice

This equipment has been tested and found to comply with the limits for a Class A digital device, pursuant to part 15 of the FCC Rules. Operation is subject to the following two conditions: (1) this device may not cause harmful interference, and (2) this device must accept any interference received, including interference that may cause undesired operation. The Class A limits are designed to provide reasonable protection against harmful interference when the equipment is operated in a commercial environment. This equipment generates, uses, and can radiate radio frequency energy and, if not installed and used in accordance with the instruction manual, may cause harmful interference to radio communications. Operation of this equipment in a residential area is likely to cause harmful interference, in which case the user will be required to correct the interference at his own expense.

NOTE *This unit was tested with shielded cables on the peripheral devices. Shielded cables must be used with the unit to ensure compliance with FCC emissions limits.*

Table of Contents

Chapter One • Introduction	1-1
About This Manual	1-2
About the SW8/12 VGA Ars Switchers	1-2
Features	1-3
Chapter Two • Installation and Operation	2-1
Mounting the SW8/12 VGA Ars Switcher	2-2
Desktop placement	2-2
Rack mounting	2-2
UL guidelines for rack mounting	2-2
Mounting instructions	2-3
Mounting under a desktop	2-4
Mounting through a desktop	2-5
Rear Panel	2-6
Cable Connections	2-7
Power connection	2-7
Computer video input connections	2-7
Audio input connections	2-8
Video output connections	2-8
Audio output connections	2-9
Remote control connection	2-9
VSW I AAP connection	2-10
IR 102 remote control connection	2-12
Front Panel	2-13
Operating the SW8/12 VGA Ars Switchers	2-14
Chapter Three • Control	3-1
Remote Control via Simple Instruction Set (SIS™)	3-2
Switcher-initiated (unsolicited) messages	3-2
Error responses	3-3
Timeout	3-3
Using the command/response table	3-3
Symbol definitions	3-3
Command/Response Table for SIS commands	3-4
Updating Firmware	3-6
Downloading the firmware	3-6
Loading the firmware to the switcher	3-7

Table of Contents, cont'd

- Appendix A • Specifications, Part Numbers, Accessories** A-1
 - Specifications** A-2
 - Part Numbers and Accessories**..... A-5
 - SW8/12 VGA Ars switchers..... A-5
 - Included parts..... A-5
 - Cables and Adapters..... A-5
 - Accessories A-5

All trademarks mentioned in this manual are the properties of their respective owners.



SW8/12 VGA Ars

1 Chapter One

Introduction

About This Manual

About the SW8/12 VGA Ars Switchers

Features

Introduction

About This Manual

This manual describes the function, installation, operation, and control of the SW8 VGA Ars and SW12 VGA Ars, 8- or 12-input, 2-output, computer video (VGA) and audio switchers.

About the SW8/12 VGA Ars Switchers

The Extron SW8/12 VGA Ars switchers support audio video (A/V) systems that require 8 or 12 high resolution VGA-QXGA video and audio inputs to be switched to 1 or 2 outputs.

Video and audio outputs are buffered. Selected input signals are delivered to both video outputs and both audio outputs simultaneously.

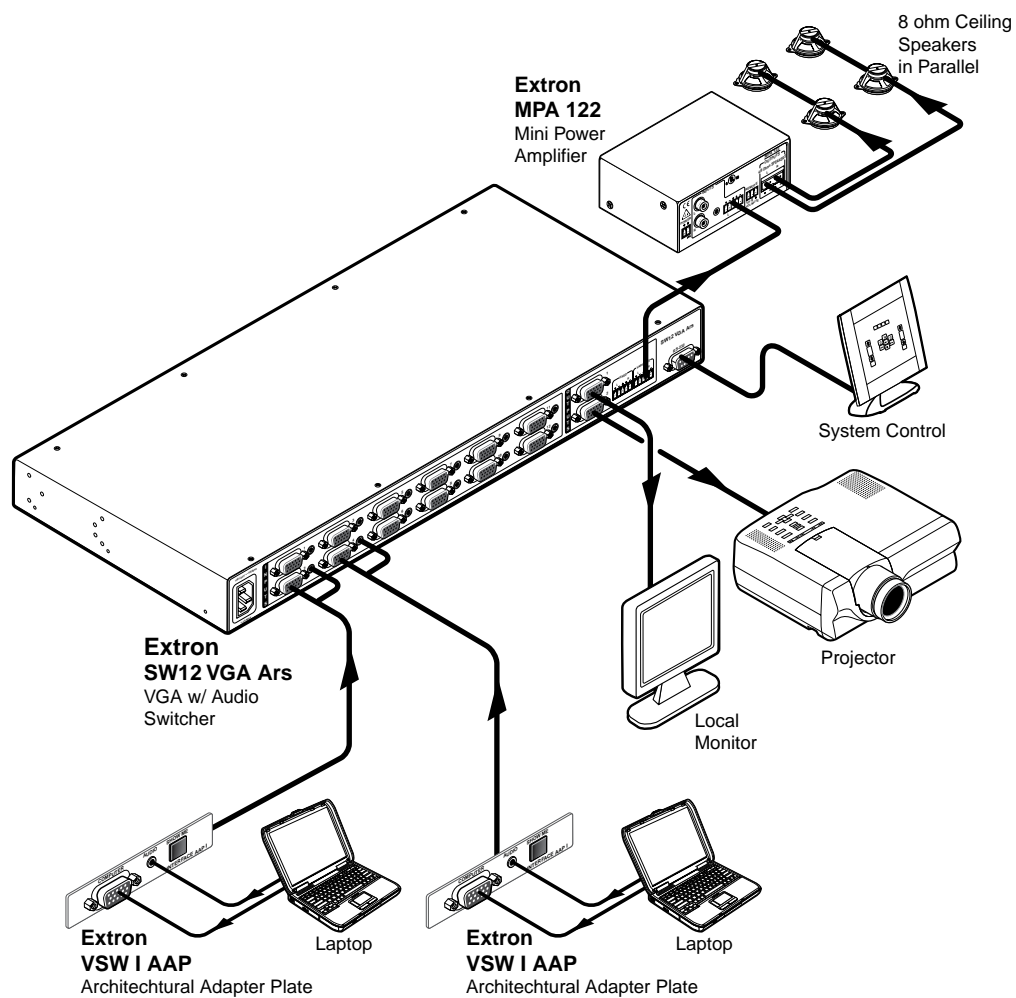

Figure 1-1 — A typical SW12 VGA Ars switcher application

Features

SW8/12 VGA Ars switcher features include:

- 8 or 12 video inputs with 15-pin HD connectors
- 8 or 12 3.5 mm stereo mini jacks for audio
- Two 15-pin HD output connectors for video
- Two captive screw output connectors for audio
- Compatible with VGA-QXGA and HDTV component video signals
- 350 MHz (-3 dB) RGB video bandwidth
- Automatically detects which inputs have an active signal and reports this information through the RS-232 port
- Balanced / unbalanced audio outputs
- Variable / fixed audio outputs
- Autoswitching capabilities
- Executive mode (front panel lockout)
- Multiple control options — front panel, autoswitch, RS-232, IR via IR 102
- VSW I AAP compatibility
- Internal international power supply
- Multiple mounting options — rack, under desk, through desk, tabletop

Introduction, cont'd



SW8/12 VGA Ars

Chapter Two

Installation and Operation

Mounting the SW8/12 VGA Ars Switcher

Rear Panel

Cable Connections

Front Panel

Operating the SW8/12 VGA Ars Switchers

Installation and Operation

Mounting the SW8/12 VGA Ars Switcher

The SW8/12 VGA Ars can be placed on a desktop or easily mounted:

- In a rack
- Under a desktop
- Through a desktop

Desktop placement

Affix the four included rubber feet to the bottom of the unit and place it in any convenient location.

Rack mounting

UL guidelines for rack mounting

The following Underwriters Laboratories (UL) guidelines pertain to the installation of an SW8/12 VGA Ars switcher unit onto a rack.

1. **Elevated operating ambient** — If installed in a closed or multi-unit rack assembly, the operating ambient temperature of the rack environment may be greater than room ambient. Therefore, consider installing the equipment in an environment compatible with the maximum ambient temperature specified by Extron ($T_{ma} = +32$ to $+122$ °F [0 to $+50$ °C]).
2. **Reduced air flow** — Installation of the equipment in a rack should be such that the amount of air flow required for safe operation of the equipment is not compromised.
3. **Mechanical loading** — Mounting of the equipment in the rack should be such that a hazardous condition is not achieved due to uneven mechanical loading.
4. **Circuit overloading** — Consideration should be given to the connection of the equipment to the supply circuit and the effect that overloading of the circuits might have on overcurrent protection and supply wiring. Appropriate consideration of equipment nameplate ratings should be used when addressing this concern.
5. **Reliable earthing (grounding)** — Reliable earthing of rack-mounted equipment should be maintained. Particular attention should be given to supply connections other than direct connections to the branch circuit (such as the use of power strips).

Mounting instructions

Rack mounting requires the included MBD 149 1U, through-desk and rack mounting kit (part #70-077-03).

Rack mount an SW8/12 VGA Ars unit as follows:

1. If present, remove the four rubber feet from the bottom of the unit.
2. Use four supplied 8-32 x 5/16" long screws to secure a mounting bracket to each side of the unit (figure 2-1).
3. Use four supplied 10-32 x 3/4" long screws to secure the bracket to the rail.

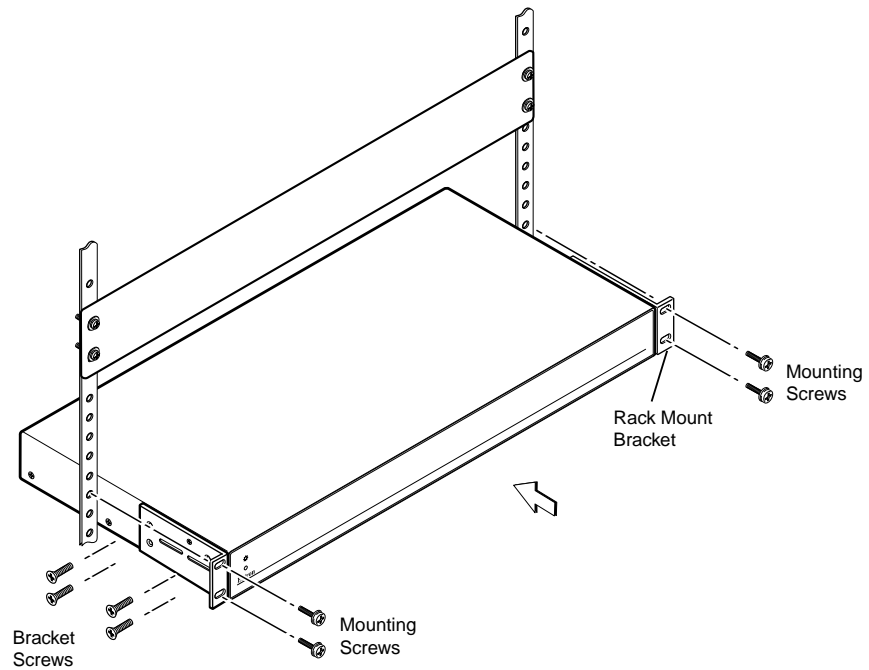

Figure 2-1 — Rack mounting the switcher

Installation and Operation, cont'd

Mounting under a desktop

Under-desk mounting requires the optional MBU 149 1U, under-desk mounting kit (part #70-222-01).

Mount an SW8/12 VGA Ars under a desktop as follows:

1. Install the mounting brackets on the unit's sides with the eight machine screws provided in the kit.
2. Hold the unit (with brackets attached) against the underside of the desk. Mark each bracket's hole location on the underside of the desk.
3. Drill 1/4" (6.4 mm) deep, 3/32" (2 mm) diameter pilot holes from the underside of the desk at the marked hole locations.
4. Insert the four wood screws into the pilot holes and tighten until approximately 1/4" (6.4 mm) of the screw's head is protruding.
5. Install the mounting brackets, with the unit attached, over the protruding screw heads.
6. Slide the unit slightly to lock it in place.
7. Tighten all four screws to secure it in place.

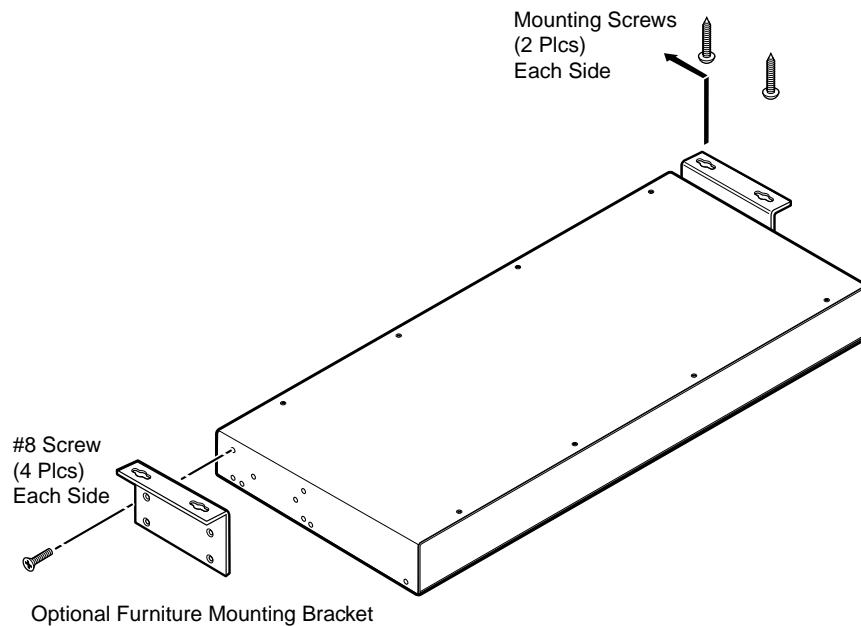

Figure 2-2 — Mounting the switcher under a desktop

Mounting through a desktop

Through desktop mounting requires the included MBD 149 1U, through-desk and rack mounting kit (part #70-077-03).

Mount an SW8/12 VGA Ars unit through a desktop as follows:

1. If present, remove the four rubber feet from the bottom of the unit.
2. Cut an appropriately sized hole in the desktop.
3. Loosely install the mounting brackets on the unit's sides with four machine screws provided in the kit.
4. Hold the unit (with brackets attached) against the underside of the desk. Mark each bracket's hole location on the underside of the desk.
5. Drill 1/4" (6.4 mm) deep, 3/32" (2 mm) diameter pilot holes from the underside of the desk at the marked hole locations.
6. Hold the unit in place so the mounting bracket holes line up with the pilot holes in the desktop.
7. Install the four supplied wood screws through the mounting brackets and into the pilot holes.
8. Tighten the wood screws to secure the mounting brackets to the underside of the desktop.
9. Slide the switcher up or down inside the mounting brackets to achieve the desired height above the desktop.
10. Tighten the machine screws to secure the switcher in position.

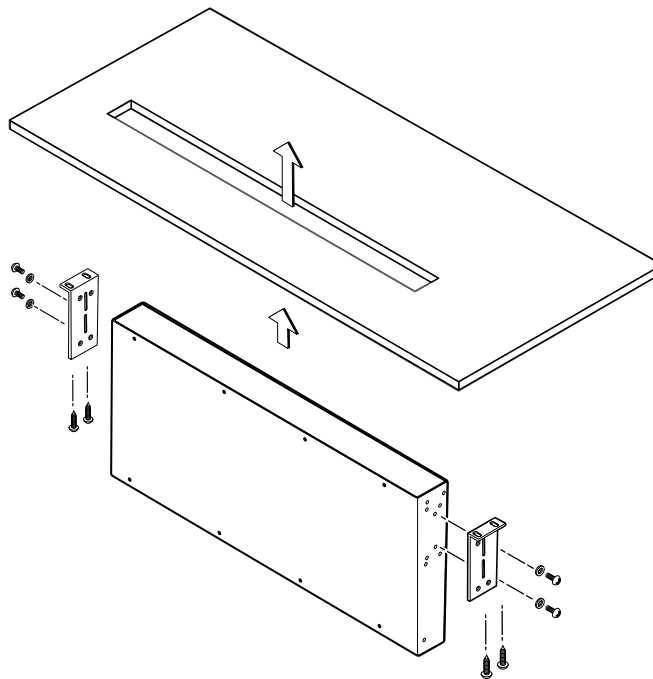

Figure 2-3 — Mounting the switcher through a desktop

Installation and Operation, cont'd

Rear Panel

The SW8/12 VGA Ars switcher rear panel connectors are described below.

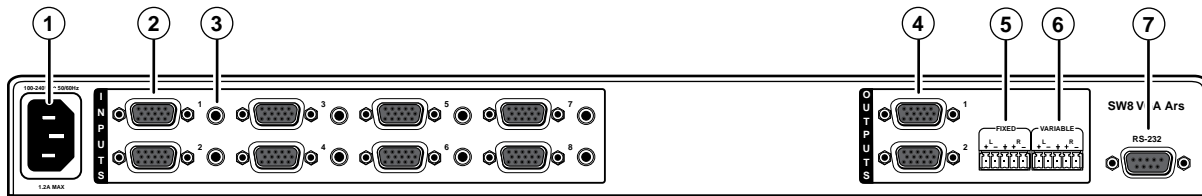

Figure 2-4 — SW8 VGA Ars rear panel

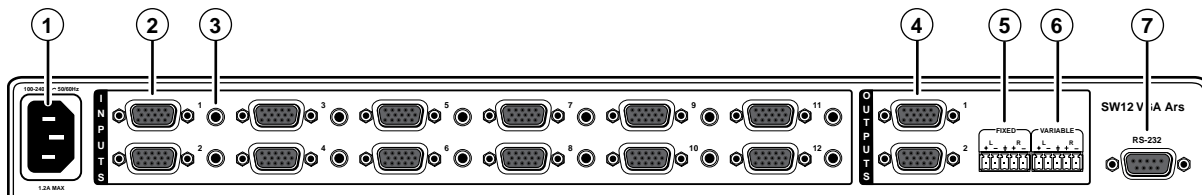

Figure 2-5 — SW12 VGA Ars rear panel

- ① **AC power receptacle** — Plug a standard IEC power cord into this receptacle to connect the switcher to a 120/240 VAC, 50/60 Hz power source.
- ② **Computer video input connectors** — 8 or 12 15-pin HD female connectors. Connect computer video inputs (VGA, SVGA, XGA, SXGA, WXGA, SXGA+, UXGA, QXGA, or HDTV).
- ③ **Audio input connectors** — Eight or twelve 3.5mm TRS jacks. Connect unbalanced audio inputs.
- ④ **Video output connectors** — Two 15-pin HD female connectors deliver simultaneous buffered video output.
- ⑤ **Fixed audio output connector** — One 3.5mm 5-pole captive screw connector delivers a fixed volume stereo balanced/unbalanced audio output.
- ⑥ **Variable audio output connector** — One 3.5mm 5-pole captive screw connector delivers a variable volume stereo balanced/unbalanced audio output. Volume is variable via the RS-232 control port. The volume adjustment range is 0 (-84 dB) through 100 (0 dB). The default volume setting is 100 (0 dB).
- ⑦ **RS-232 Control port** — A 9-pin D female connector for serial connection to a PC or controller.

Cable Connections

Power connection

When you are ready to apply power to your SW8/12 VGA Ars unit, connect the female end of the power cord to the AC outlet at the left edge of the rear panel, and connect the male end of the power cord to a 120/240 VAC power outlet.

When power is applied all front panel LEDs light for one second, then go out. The LED for the previously selected input then comes on and remains lit until the current input is de-selected.

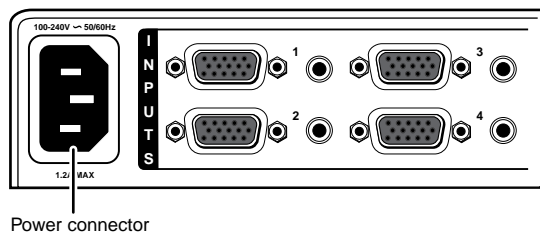

Power connector

Figure 2-6 — Power connector

Computer video input connections

Depending on the model (SW8 or SW12) there are 8 or 12 video input ports on the rear panel.

Each 15-pin HD female connector supports computer video signals with resolutions from VGA - QXGA and HDTV signals.

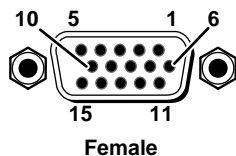

Figure 2-7 Video input connectors

SW8/12 VGA Ars switchers monitor each input port for the presence of a horizontal sync pulse, which indicates the presence of a video signal. When detected, the video signal's presence is reported on the switcher's RS-232 control port. See chapter 3, "Operation and Control" for information on the Simple Instruction Set (SIS™) commands which can be used to communicate through the RS-232 port.

The SIS command `0S` requests the switcher to report the status of all inputs at once.

The SIS command `xS` requests the status of specific port "x".

Installation and Operation, cont'd

Audio input connections

The switchers have 8 or 12 3.5mm female audio jacks adjacent to the corresponding computer video input port.

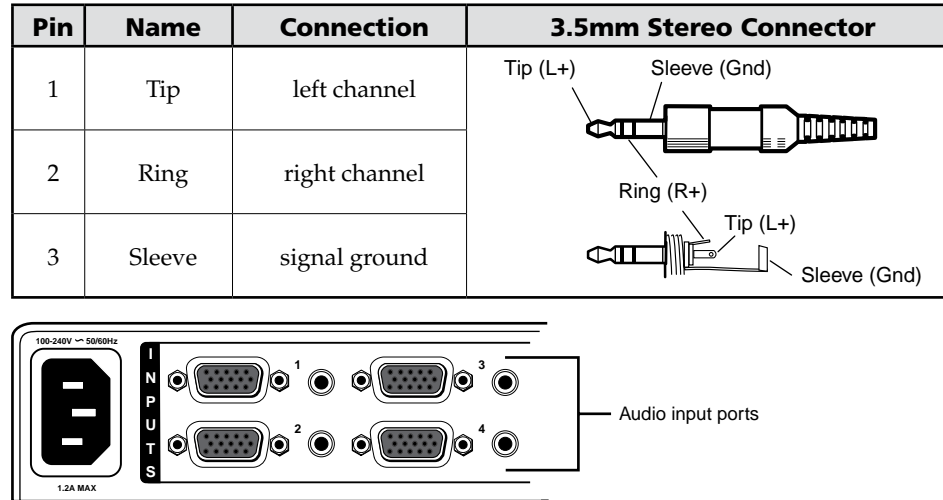

Figure 2-8 — Audio input ports

Video output connections

The SW8/12 VGA Ars switchers have two output ports that provide simultaneous, buffered video output of the selected video input signal.

Outputs are delivered on two 15-pin HD female connectors (identical to the input connectors). The output signal type follows the input signal type.

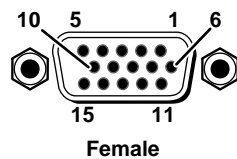

Figure 2-9 — Video output connectors

ID bits associated with pins 4, 11, 12, and 15 are routed from the input 1 to output 1.

The output device must be powered on prior to the input device for the ID bits to be properly routed to the output device.

Audio output connections

The switcher have two 3.5mm 5-pole captive screw audio output ports.

The Fixed port delivers a fixed volume, stereo balanced/unbalanced audio output.

The Variable port delivers a variable volume, stereo balanced/unbalanced audio output. The volume range is 0 (-84 dB) through 100 (0 dB). The default volume setting is 100 (0 dB). Volume is controllable only via the RS-232 port.

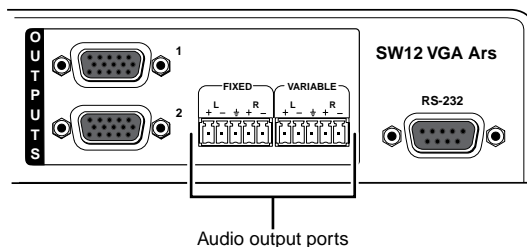

Figure 2-10 — Audio output ports

Wire the captive screw connectors as shown below.

CAUTION Connect the sleeve to ground (⊕). Connecting the sleeve to a negative (-) terminal will damage the audio output circuits.

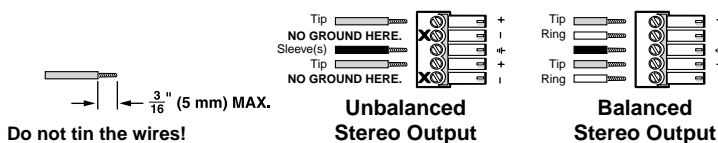

Figure 2-11 — Captive screw connectors

NOTE A balanced audio output provides a +6 dB gain. An unbalanced audio output provides a 0 dB gain.

Remote control connection

An RS-232 serial control port at the right edge of the rear panel is used for computer or infrared (IR) remote control of the device. The switcher's firmware can be upgraded through the RS-232 port. See chapter 3, "Operation and Control".

The RS-232 port communications protocols are: 9600 baud, 8 data bits, 1 stop bit, no parity, and no flow control.

IR remote control requires use of the IR 102 Remote Control Kit (part #70-224-01)

For computer or infrared remote control, only pins 2 (transmit data), 3 (receive data), and 5 (ground) are required. Disconnect all other conductors in the attachment cable for proper operation.

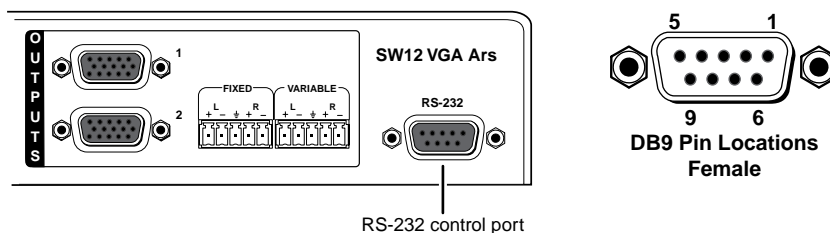

Figure 2-12 — RS-232 control port

Installation and Operation, cont'd

VSW I AAP connection

The VSW I AAP (part #70-529-11, -21, -51) is an optional Architectural Adapter Plate that provides remote input connection and selection for some Extron switchers.

The VSW I AAP can be connected to the SW8/12 VGA Ars input ports for input selection control.

The VSW I AAP is equipped with a “Show Me” button for input selection, a female 15-pin HD VGA connector, and a 3.5 mm stereo audio jack.



Figure 2-13 — VSW I AAP

When the “Show Me” button is pressed, pin 5 on the switcher’s 15-pin HD input is momentarily shorted to ground. This overrides the switcher’s current input selection, and directs video and audio from the VSW I AAP’s connected device to the switcher’s output ports.

For the VSW I AAP to operate with a switcher, the VSW I AAP PCB jumper must be set properly, and the switcher must be configured via its RS-232 control port.

The VSW I AAP can be mounted into any Extron mounting frame with a single space AAP opening.

The illustration on the following page shows a typical SW8 VGA Ars switcher application with four VSW I AAP units connected to the switcher’s input ports.

To use a VSW I AAP with a switcher:

1. Confirm that jumper J5 is removed and jumper J6 is in place on the VSW I AAP’s printed circuit board.

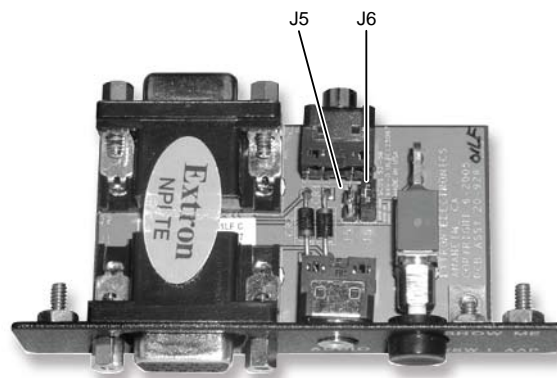

Figure 2-14 — VSW I AAP jumpers

2. Apply power to the switcher.
3. Connect a host computer to the switcher’s RS-232 control port.
4. Open a hyperterminal session on the host computer, and use a Simple Instruction Set (SIS™) command to configure the switcher to operate with a VSW I AAP (see chapter 3, “Operation and Control”).
5. Connect a VGA cable from the VSW I AAP’s output connector (on the rear of the unit) to one of the switcher’s input ports.

6. Connect a VGA cable from an input device to the Computer input port on the front of the VSW I AAP.
7. Apply power to the display device, the switcher, and then the input source.
8. Press the “Show Me” button on the VSW I AAP. The video input to the VSW I AAP is directed to the switcher’s output ports and should now be present on the display device.
9. If desired, connect an audio input to the VSW I AAP, and use the “Show Me” button to test its output to the system’s audio output device.

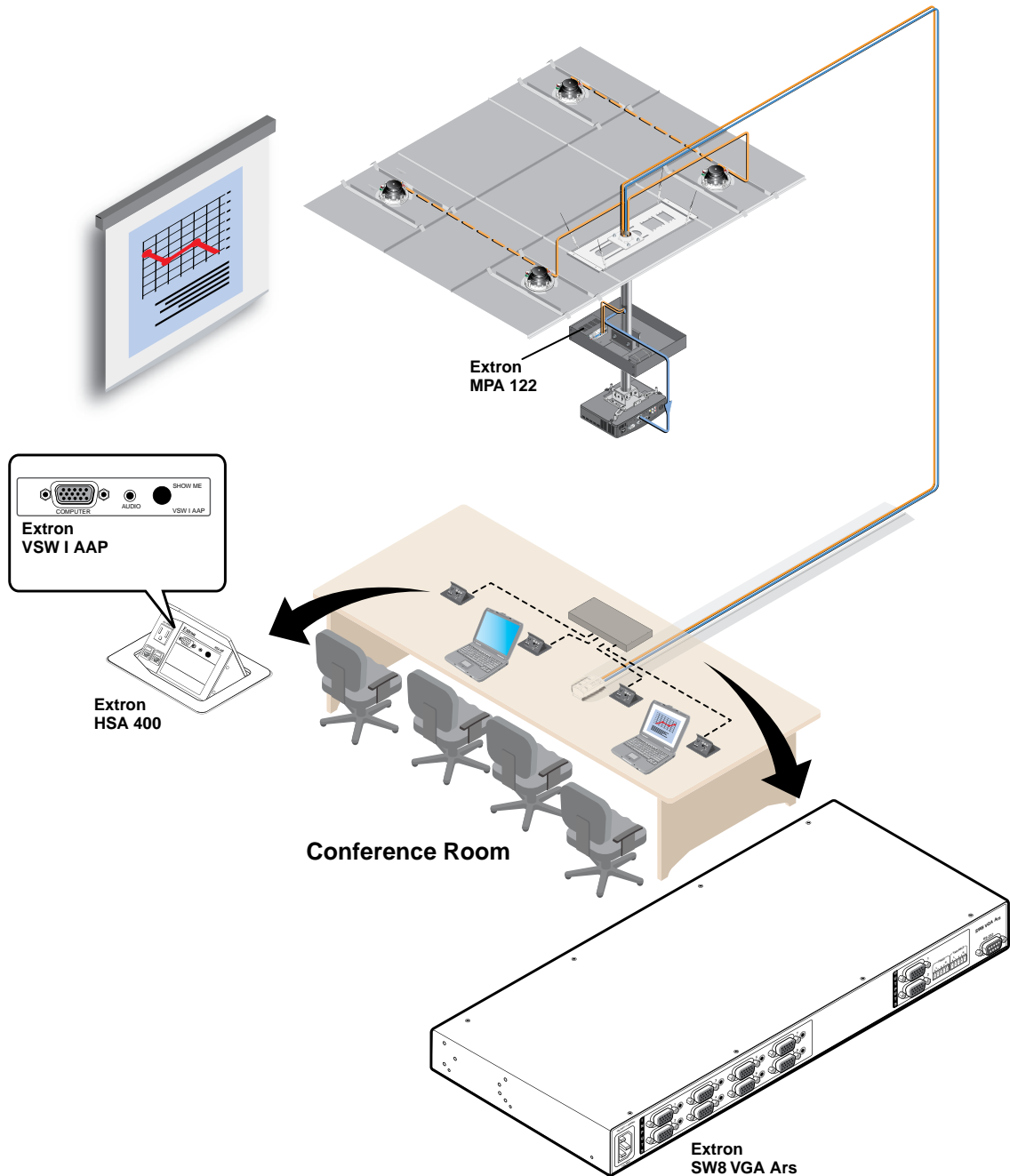

Figure 2-15 — A typical switcher application with VSW I AAP units

Installation and Operation, cont'd

IR 102 remote control connection

The SW8/12 VGA Ars switcher can be controlled via its RS-232 port and an infrared signal. The IR 102 Remote Control Kit (part #70-224-01) is required.

To connect an IR 102 Receiver to an SW8/12 VGA Ars switcher:

1. Connect a 9-pin serial cable, with only conductors 2, 3, and 5 connected, to the RS-232 output port on the IR 102 receiver.
2. Connect the serial cable to the RS-232 port on the switcher's rear panel.

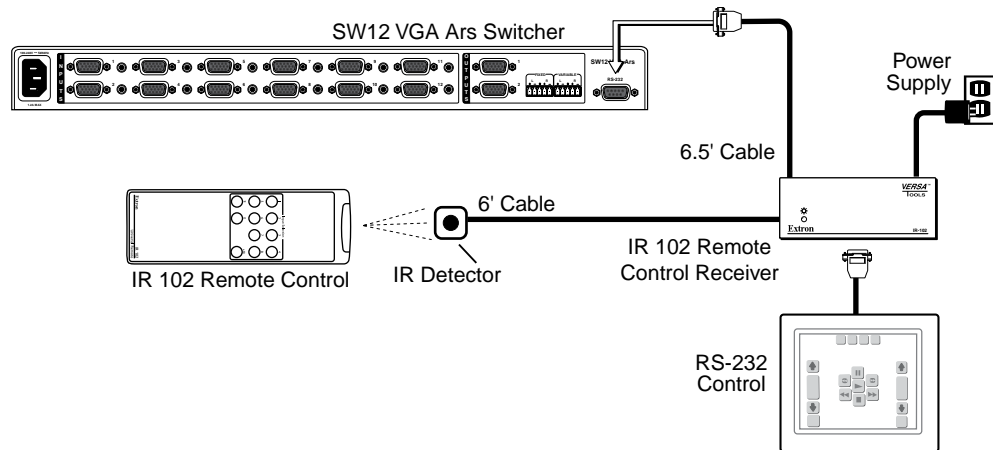

Figure 2-16 — A typical switcher application w/IR 102 remote control

Front Panel

The SW8/12 VGA Ars switcher front panel controls are described below.

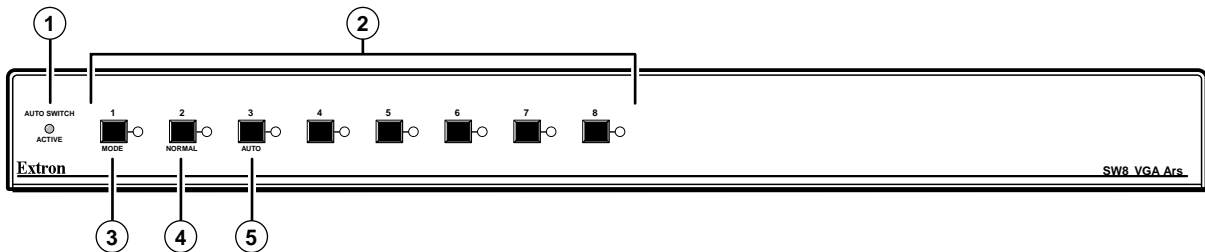

Figure 2-17 — SW8 VGA Ars front panel

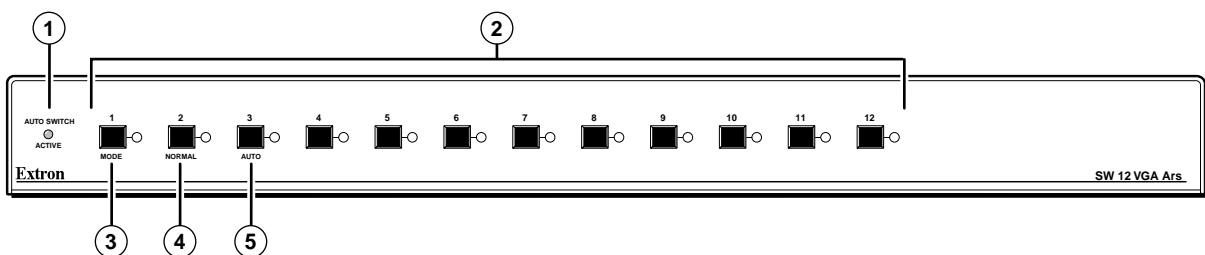

Figure 2-18 — SW12 VGA Ars front panel

- ① **Auto switch active LED** — Lights when the auto switch mode is enabled.
- ② **Input buttons and LEDs**— Depending on the model there are eight or twelve input buttons and corresponding LEDs. To select an input, press the desired input button. The adjacent LED lights.
- ③ **Mode (Input 1) button** — The **Mode** button functions in conjunction with other buttons as shown in the table below. Mode is a secondary function of the Input 1 button.

Hold	Press	Description and Result
Mode	Normal	Enable Normal mode — Front panel input buttons operate normally. Auto Switch Active LED is off.
Mode	Auto	Enable Auto switch mode — Front panel input buttons are locked out. Switcher outputs highest number input that has a sync signal present. If no sync signal is present, input #1 is selected by default. Auto Switch Active LED is on.
Mode	Input button #4 for 3 sec.	Enable/disable Executive mode — All LEDs flash 3 times. All front panel input buttons are locked out. Attempts to select an input button causes all LEDs to flash. Input selections via RS-232 and VSW IAAP still function. Disable Executive mode — All LEDs flash three times, and the front panel input buttons return to operation.
Mode - while applying power		Perform factory reset — Reset unit to its factory settings.

- ④ **Normal (Input 2) button** — Hold **Mode** and press **Normal** to have the front panel input buttons operate in manual mode - press an input button to select an input signal.

Installation and Operation, cont'd

- ⑤ **Auto (Input 3) button** — Hold **Mode** and press **Auto** to lock out the front panel input buttons and have the switcher select the highest number input with a sync signal present as its output. If no sync signal is present, input #1 is selected by default.

Operating the SW8/12 VGA Ars Switchers

After power-on the following operations are available:

Video / audio input selection — Press an input selection button to send the connected video and audio input signals to the output devices. When an input is selected, the adjacent LED lights.

- The SW8 VGA Ars has 8 input selection buttons.
- The SW12 VGA Ars has 12 input selection buttons.

Mode selection — See the front panel descriptions on the previous page.



SW8/12 VGA Ars

Chapter Three

Control

Remote control via Simple Instruction Set (SIS™)

Updating Firmware

Control

Remote Control via Simple Instruction Set (SIS™)

The SW8/12 VGA Ars switchers can be controlled via RS-232 using Extron's Simple Instruction Set (SIS) commands.

The RS-232 port communications protocols are: 9600 baud, 8 data bits, 1 stop bit, no parity, and no flow control. Cable pinouts are shown in the table below.

Only pins 2, 3, and 5 are required. Disconnect all other conductors in the attachment cable for proper operation.

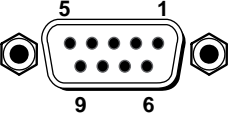
Pin	RS-232	Description	RS-232 Control Port Connector
1	—	—	 <p>DB9 Pin Locations Female</p>
2	Tx	Transmit data	
3	Rx	Receive data	
4	—	—	
5	Gnd	Signal ground	
6	—	—	
7	—	—	
8	—	—	
9	—	—	

Rules governing SIS commands include:

- SIS commands consist of one or more characters per field.
- No special characters are required to begin or end a command sequence.
- When a command is valid, the switcher executes the command and sends a response to the host device.
- All responses from the switcher to the host end with a carriage return and a line feed (CR/LF = \leftarrow), which signals the end of a response character string.
- A string is one or more characters.

Switcher-initiated (unsolicited) messages

When a local event, such as a front panel operation or error condition, occurs, the switcher responds by sending a message to the host. Switcher-initiated messages are listed below:

(C) Copyright 2008, Extron Electronics SW y VGA Ars, V $x.xx$ \leftarrow

The switcher issues the copyright message when it first powers on.

y = the number of inputs (8 or 12, depending on the model)

$x.xx$ = the firmware version number

Error responses

When the switcher receives a valid command, it executes the command and sends a response to the host device. If the unit is unable to execute the command because the command contains invalid parameters, it returns an error response to the host.

Error response codes are:

E01 — Invalid input channel number (out of range)

E06 — Invalid input channel change (auto-switch mode active)

E09 — Invalid function (mode) parameter

E10 — Invalid command

E13 — Invalid value (out of range)

Timeout

A pause of 10 seconds or longer between command ASCII characters results in a timeout. The command operation is aborted with no other indication.

Using the command/response table

The command/response table is on the following pages. Lowercase letters are allowed in the command field only as indicated. Symbols are used throughout the table to represent variables in the command/response fields. Command and response examples are shown throughout the table. The ASCII to HEX conversion table below is for use with the command/response table.

ASCII to HEX Conversion Table										Esc 1B	CR 0D	LF 0A		
Space 20	!	21	"	22	#	23	\$	24	%	25	&	26	'	27
(28)	29	*	2A	+	2B	,	2C	-	2D	.	2E	/	2F
0 30	1	31	2	32	3	33	4	34	5	35	6	36	7	37
8 38	9	39	:	3A	;	3B	<	3C	=	3D	>	3E	?	3F
@ 40	A	41	B	42	C	43	D	44	E	45	F	46	G	47
H 48	I	49	J	4A	K	4B	L	4C	M	4D	N	4E	O	4F
P 50	Q	51	R	52	S	53	T	54	U	55	V	56	W	57
X 58	Y	59	Z	5A	[5B	\	5C]	5D	^	5E	_	5F
` 60	a	61	b	62	c	63	d	64	e	65	f	66	g	67
h 68	i	69	j	6A	k	6B	l	6C	m	6D	n	6E	o	6F
p 70	q	71	r	72	s	73	t	74	u	75	v	76	w	77
x 78	y	79	z	7A	{	7B		7C	}	7D	~	7E	DEL	7F

Figure 3-1 — ASCII-to-HEX conversion table

Symbol definitions

↵ = CR/LF (carriage return/line feed)

← = Carriage return (no line feed)

• = Space character

X1 = Input number
 SW8 = 0 through 8
 SW12 = 0 through 12
 0 = output mute

X2 = Indicates signal presence
 0 = signal not present
 1 = signal is present

X3 = On/off status
 0 = off
 1 = on

X4 = Volume value/range
 0 - 100

X5 = Switch mode
 1 = normal mode
 2 = auto switch mode

Control, cont'd

Command/Response Table for SIS commands

Command	ASCII (Telnet) (host to switcher)	Response (switcher to host)	Additional description
Input Selection			
Select video and audio	X1 !	In X1 All←	Select input X1 video and audio.
Select video only	X1 &	In X1 Vid←	Select input X1 video only.
Select audio only	X1 \$	In X1 Aud←	Select input X1 audio only.
Auto Switch			
Normal switch mode	1#	F1←	Set switch mode to normal.
Auto switch mode	2#	F2←	Set switch mode to auto.
Input video sensing			
Request all inputs' status	0S	Sig• X2 • X2 .. X2 ←	Each X2 response is the signal status from each input X1 's signal status.
<i>Example: (SW8)</i>	0S	Sig•1•1•1•1•0•1•1•0←	The input signal is present on inputs 1,2,3,4,6, and 7. No signal is present on inputs 5 and 8.
Request specific input's status	X1 S	X2 ←	X1 's signal status = X2 .
Video mute			
NOTE These commands mute and unmute both video outputs.			
Mute video	1B/b	Vmt X3 ←	Video mute on.
Unmute video	0B/b	Vmt X3 ←	Video mute off.
Read mute status	B/b	X3 ←	Video mute status.
Audio mute			
NOTE These commands mute and unmute both audio outputs.			
Mute audio	1Z/z	Amt X3 ←	Audio mute on.
Unmute audio	0Z/z	Amt X3 ←	Audio mute off.
Read mute status	Z/z	X3 ←	Audio mute status.
Output Volume Control (variable audio output)			
Set audio volume to a specific level	X4 V	Vol X4 ←	
<i>Example:</i>	75V	Vol75←	Sets output volume to 75.
Increment volume	+V	Vol X4 ←	
Decrement volume	-V	Vol X4 ←	
View volume	V	X4 ←	
VSW I AAP Compatibility Mode			
Enable/disable single input	Esc X1 * X3 VSWE←	Vswe• X3 • X3 • X3• X3 ←	X1 is an input (1-8 or 1-12).
Enable/disable all inputs	Esc 0* X3 VSWE←	Vswe• X3 • X3 • X3• X3 ←	X3 is the enabled/disabled status from each input (0 = disabled, 1 = enabled).
View current status	Esc VSWE←	Vswe• X3 • X3 • X3• X3 ←	
Front panel lockout			
Turn front panel lockout on	1X/x	Exe X3 ←	Front panel lockout on.
Turn front panel lockout off	0X/x	Exe X3 ←	Front panel lockout off.
View front panel lockout status	X/x	X3 ←	Front panel lockout status.

Command/Response Table for SIS commands (continued)

Command	ASCII (Telnet) (host to switcher)	Response (switcher to host)	Additional description
View information, part number, and firmware requests			
Information request	I/i	V[x1]•A[x1]•F[x5]•Vmt[x3]•Amt[x3]↵	Current video/audio selection/ switch mode /mute status.
Request part number	N/n	60-xxx-21↵	x = part number
Query firmware revision	Q/q	y.yy↵	y.yy = firmware to two decimals
Upload firmware			
Upload firmware	EscUpload←	...go ... Upl↵	“Upl” appears after the upload is complete.
Reset			
Reset switcher to factory settings	EsczXXX←	Zpx↵	
Reset audio output level	EsczV←	Zpv↵	Reset output volume to 100.

Updating Firmware

Firmware updates for the SW8/12 VGA Ars are available on the Extron Web site, www.extron.com. The Firmware Loader software is also available from the Extron site.

Use the SIS "Q" command to determine the switcher's current firmware level.

Downloading the firmware

To obtain the latest version of firmware for your SW8/12 VGA Ars switcher:

1. Visit the Extron Web site, www.extron.com, click the **Download** tab, then click the **Firmware** link on the left sidebar menu.

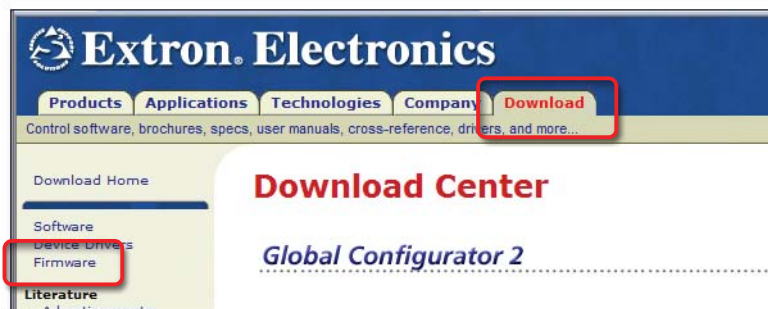

Figure 3-2 — Extron Web site Download Center

2. On the Download Center screen, click the SW8/12 VGA Series **Download** link.

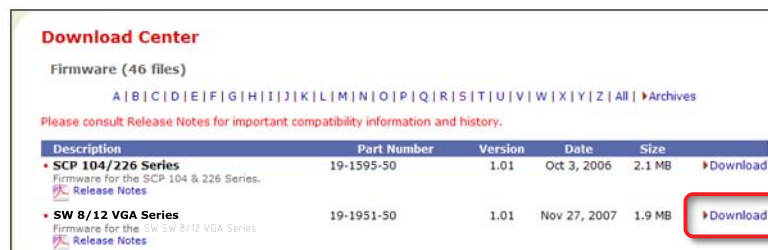
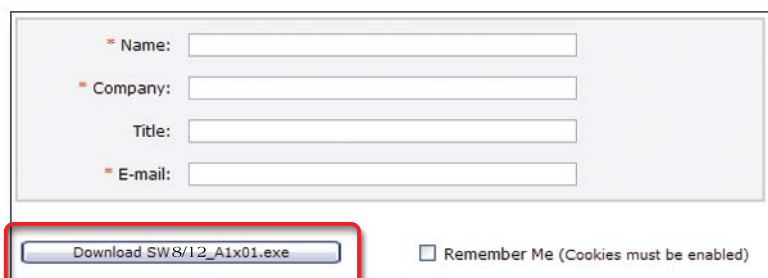

Figure 3-3 — SW8/12 VGA Ars firmware

3. Complete the Personal Information form and click the **Download** button.



* Name:

* Company:

Title:

* E-mail:

Remember Me (Cookies must be enabled)

Figure 3-4 — Personal information form

-
4. Follow the instructions on the rest of the download screens to save the executable firmware file to your computer. Note the folder to which you save the file.
 5. In the Windows Explorer or other file browser, locate the downloaded executable file, and double-click on it to open it.
 6. Follow the instructions on the Installation Wizard screens to install the new firmware on your computer. A Release Notes file, giving information on what has changed in the new firmware version, and a set of instructions for updating the firmware are also loaded.

Loading the firmware to the switcher

To load a new version of firmware to your SW8/12 VGA Ars switcher, use the Firmware Loader software. Your computer's serial port must be connected to the switcher's serial port. See chapter 2, "Installation," for more information.

1. Download the Firmware Loader installer executable file to your computer, as follows:
 - a. On the Extron Web page, click the **Download** tab.
 - b. On the Download Center page, click **Software** on the left sidebar menu.
 - c. Locate the "Firmware Loader" line and click the **Download** link at the far right.
 - d. Follow the instructions on the download screens to save the installer file to your computer.
2. In the Windows Explorer or other file browser, locate the Firmware Loader executable file in your computer's file system and double-click on it to open it.
3. Follow the instructions on the Installation Wizard screens to install the Firmware Loader on your computer. Unless you specify otherwise, the installer program places the Firmware Loader file, "FWLoader.exe" at **c:\Program Files\Extron\FWLoader**

(If the Extron and FWLoader folders do not yet exist in your Program Files folder, the installer creates them.)
4. Access the FWLoader.exe file via your desktop Start menu by making the following selections:
Start > All Programs > Extron Electronics > Firmware Loader > Firmware Loader
5. On the first screen that appears, select the RS-232 tab.
NOTE *Although the screen also has a TCP/IP tab, the switcher does not have a LAN port. Do not select the TCP/IP tab.*
6. From the drop-down menus on the RS-232 screen, select the appropriate Com port number (obtained from your system administrator) and baud rate (the default is 9600). (The **Device** selection is optional.)

Control, cont'd

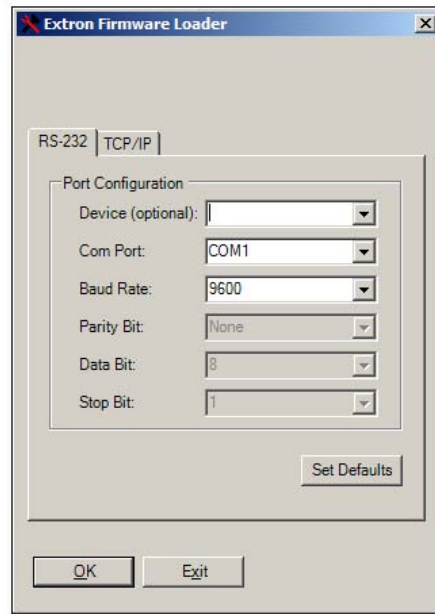

Figure 3-5 — Extron firmware loader screen

7. Click **OK**. The firmware selection screen appears.
8. On the firmware selection screen, click Browse to open the Choose Firmware File window, and locate the firmware file that you downloaded. (By default, the firmware file is placed at c: Program Files\Extron\Firmware\SW when downloaded from the Extron Web site, www.extron.com.)

CAUTION *The firmware file must have a .s19 extension. Uploading any other file type could cause the switcher to stop functioning.*

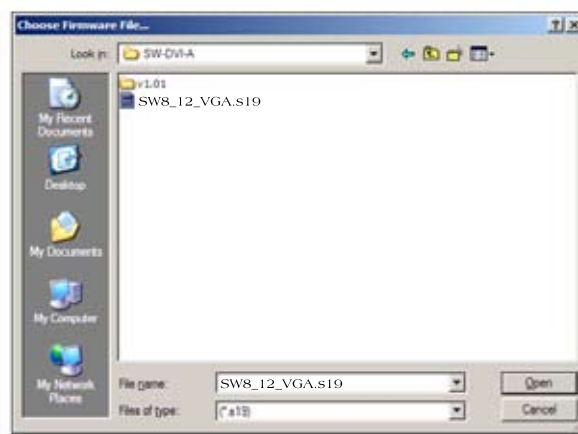

Figure 3-6 — Choose firmware file screen

-
9. On the Choose Firmware File window, double-click on the new firmware file to open it. The Choose Firmware File window closes, and the path to the selected firmware file is displayed in the “Select a firmware file” field on the firmware file selection screen.



Figure 3-7 — Extron's firmware loader screen

10. Click the **Upload** button. A status bar, which shows the progress of the upload, appears in the Firmware Loader window. The firmware upload to the switcher may take several minutes. Once the status bar has progressed fully from left to right, the firmware loader utility resets the switcher.

In addition, messages appear on the firmware file selection window indicating when the unit is uploading the firmware, then resetting itself.

When the firmware upload process is completed, the message “Transfer Complete!” is displayed, and the new firmware version number appears in the Current Unit Information field.

11. Click **Exit** to close the Firmware Loader.

Control, cont'd



SW8/12 VGA Ars

A

Appendix A

Specifications, Part Numbers, Accessories

Specifications

Part Numbers and Accessories

Specifications, Part Numbers, Accessories

Specifications

Video

Gain.....	Unity
Bandwidth.....	350 MHz (-3 dB)
Crosstalk.....	-68 dB @ 10 MHz

Video input

Number/signal type.....	8 or 12 (depending on the model) VGA-QXGA RGBHV, RGBS, RGsB, RsGsBs computer video, and HDTV component video
Connectors	8 or 12 female 15-pin HD
Nominal level	1.0 Vp-p for Y of component video 0.7 Vp-p for RGB and for R-Y and B-Y of component video
Minimum/maximum levels.....	Analog: 0.3 V to 1.5 Vp-p with no offset
Impedance.....	75 ohms
Horizontal frequency.....	15 kHz to 145 kHz
Vertical frequency.....	30 Hz to 170 Hz
Return loss.....	-40 dB @ 5 MHz
Input coupling.....	DC

Video output

Number/signal type.....	2 VGA-QXGA RGBHV, RGBS, RGsB, RsGsBs computer video, and HDTV component video (follows input type)
Connectors	2 female 15-pin HD
Nominal level	1.0 Vp-p for Y of component video 0.7 Vp-p for RGB and for R-Y and B-Y of component video
Minimum/maximum levels.....	0.3 V to 1.5 Vp-p (follows input)
Impedance.....	75 ohms
Return loss.....	-43 dB @ 5 MHz
DC offset.....	±5 mV with input at 0 offset

Sync

Input type.....	RGBHV, RGBS, RGsB, RsGsBs, bi-level and tri-level sync
Output type.....	RGBHV, RGBS, RGsB, RsGsBs, bi-level and tri-level sync (follows input)
Input level	1.0 V to 5.0 Vp-p
Output level	TTL: 5.0 Vp-p, unterminated
Input impedance	510 ohms
Output impedance	75 ohms
Max. propagation delay	
SW2/4/6 VGA Series	47 ns
SW8/12 VGA Series.....	54 ns
Max. rise/fall time	
SW2/4/6 VGA Series	4.2 ns
SW8/12 VGA Series.....	4.7 ns
Polarity.....	Positive or negative (follows input)

Audio

Gain.....	Unbalanced output: +0 dB; balanced output: +6 dB
Frequency response	20 Hz to 20 kHz, ± 0.05 dB
THD + Noise.....	0.01% @ 1 kHz at nominal level
S/N.....	>90 dB at maximum output (unweighted)
Crosstalk.....	-45 dB @ 1 kHz, fully loaded
Stereo channel separation	>80 dB 1 kHz

Audio input

Number/signal type.....	8 or 12 (depending on the model) stereo, unbalanced
Connectors	8 or 12 (depending on the model) 3.5 mm female stereo mini jacks; tip (L), ring (R), sleeve (Gnd)
Impedance.....	>10k ohms unbalanced, DC coupled
Nominal level	-10 dBV (316 mV)
Maximum level.....	+14 dBV, (unbalanced) at 1% THD+N

NOTE $0\text{ dBu} = 0.775\text{ Vrms}$, $0\text{ dBV} = 1\text{ Vrms}$, $0\text{ dBV} \approx 2\text{ dBu}$

Audio output

Number/signal type.....	2 stereo, balanced/unbalanced
Connectors	(2) 3.5 mm captive screw connectors, 5 pole
Impedance.....	50 ohms unbalanced, 100 ohms balanced
Nominal level	+4 dBu (1.23 Vrms), balanced -10 dBV (316 mVrms), unbalanced
Variable output's volume range..	0 to 100 (-84 dB to 0 dB), default = 100 = 0 dB
Gain error	± 0.1 dB channel to channel
Maximum level (Hi-Z)	+28 dBu, balanced; +20 dBV, unbalanced at 1%THD+N
Maximum level (600 ohm).....	+21 dBm, balanced; +18 dBm, unbalanced at 1%THD+N

Control/remote — switcher

Serial control port.....	RS-232, 9-pin female D connector
Baud rate and protocol.....	9600 baud, 8 data bits, 1 stop bit, no parity
Serial control pin configurations.	2 = TX, 3 = RX, 5 = GND
"Show Me" contact closure.....	Pin 5 of each VGA input connector. The input is active (selected) when pin 5 momentarily goes to ground.
Program control.....	Extron's control/configuration program for Windows® Extron's Simple Instruction Set (SIS™)

Specifications, Part Numbers, Accessories, cont'd

General

Power	100 VAC to 240 VAC, 50/60 Hz, 10 watts, internal
Temperature/humidity	Storage: -40 to +158 °F (-40 to +70 °C) / 10% to 90%, noncondensing Operating: +32 to +122 °F (0 to +50 °C) / 10% to 90%, noncondensing
Cooling	Convection, no vents
Mounting	
Rack mount	Yes, with included MBD 149 bracket kit, 70-077-03
Furniture mount	Yes, with optional under-desk mounting kit, part #70-077-01 (MBU 125), or through-desk mounting kit, part #70-077-02 (MBD 129)
Enclosure type	Metal
Enclosure dimensions	1.75" H x 17.5" W x 9.5" D (1U high, full rack wide) (4.4 cm H x 44.4 cm W x 24.1 cm D) (Depth excludes connectors)
Product weight	6.3 lbs (2.9 kg)
Shipping weight	11 lbs (5 kg)
Vibration	ISTA 1A in carton (International Safe Transit Association)
Regulatory compliance	
Safety	CE, C-tick, CUL, UL
Compliances	CE, C-tick, FCC Class A, ICES, VCCI
MTBF	30,000 hours
Warranty	3 years parts and labor

NOTE All nominal levels are at $\pm 10\%$.

NOTE Specifications are subject to change without notice.

Part Numbers and Accessories

SW8/12 VGA Ars switchers

Model	Part number
SW8 VGA Ars	60-902-21
SW12 VGA Ars	60-946-21

Included parts

Description	Part number
MBD 149 rack mount and through desk mounting kit	70-077-03
5-pole, 3.5mm captive screw connector w/strain relief (10)	100-457-01
Rubber feet (4)	
IEC power cord	
Software CD (disk B)	
Audio wiring card	
Tweaker	

Cables and Adapters

Description	Part number
VGA-A M-M cable w/audio	26-490-xx
SYM BNCF 15-pin HD male to BNC female mini HR cable	26-531-xx
SYM BNCFM 15-pin HD male to BNC male mini HR cable	26-533-xx

Accessories

Description	Part number
VSW I AAP architectural adapter plate (black)	70-529-11
VSW I AAP architectural adapter plate (white)	70-529-21
VSW I AAP architectural adapter plate (RAL9010 white)	70-529-51
MBU 149 1U full rack under-desk mounting ki	70-222-01
IR 102 remote control kit	70-224-01

Specifications, Part Numbers, Accessories, cont'd

Extron's Warranty

Extron Electronics warrants this product against defects in materials and workmanship for a period of three years from the date of purchase. In the event of malfunction during the warranty period attributable directly to faulty workmanship and/or materials, Extron Electronics will, at its option, repair or replace said products or components, to whatever extent it shall deem necessary to restore said product to proper operating condition, provided that it is returned within the warranty period, with proof of purchase and description of malfunction to:

**USA, Canada, South America,
and Central America:**

Extron Electronics
1001 East Ball Road
Anaheim, CA 92805
U.S.A.

Japan: Extron Electronics, Japan
Kyodo Building, 16 Ichibancho
Chiyoda-ku, Tokyo 102-0082
Japan

Europe, Africa, and the Middle East:

Extron Europe
Hanzeboulevard 10
3825 PH Amersfoort
The Netherlands

China:

Extron China
686 Ronghua Road, Songjiang
District
Shanghai 201611
China

Asia:

Extron Asia
135 Joo Seng Road, #04-01
PM Industrial Bldg.
Singapore 368363
Singapore

Middle East:

Extron Middle East
Dubai Airport Free Zone
F12, PO Box 293666
United Arab Emirates, Dubai

This Limited Warranty does not apply if the fault has been caused by misuse, improper handling care, electrical or mechanical abuse, abnormal operating conditions or non-Extron authorized modification to the product.

If it has been determined that the product is defective, please call Extron and ask for an Applications Engineer at (714) 491-1500 (USA), 31.33.453.4040 (Europe), 65.383.4400 (Asia), or 81.3.3511.7655 (Japan) to receive an RA# (Return Authorization number). This will begin the repair process as quickly as possible.

Units must be returned insured, with shipping charges prepaid. If not insured, you assume the risk of loss or damage during shipment. Returned units must include the serial number and a description of the problem, as well as the name of the person to contact in case there are any questions.

Extron Electronics makes no further warranties either expressed or implied with respect to the product and its quality, performance, merchantability, or fitness for any particular use. In no event will Extron Electronics be liable for direct, indirect, or consequential damages resulting from any defect in this product even if Extron Electronics has been advised of such damage.

Please note that laws vary from state to state and country to country, and that some provisions of this warranty may not apply to you.

tron **USA - West**
adquarters
10.633.9876
e USA / Canada Only
714.491.1500
714.491.1517 FAX

Extron **USA - East**
+800.633.9876
Inside USA / Canada Only
+1.919.863.1794
+1.919.863.1797 FAX

Extron **Europe**
+800.3987.6673
Inside Europe Only
+31.33.453.4040
+31.33.453.4050 FAX

Extron **Asia**
+800.7339.8766
Inside Asia Only
+65.6383.4400
+65.6383.4664 FAX

Extron **Japan**
+81.3.3511.7655
+81.3.3511.7656 FAX

Extron **China**
+400.883.1568
Inside China Only
+86.21.3760.1568
+86.21.3760.1566 FAX

Extron **Middle East**
+971.4.2991800
+971.4.2991880 FAX